

Power Solution for 1500VDC Photovoltaic Power Generation System

This series of DC/DC converters accepts a wide input range from 200-1500VDC providing standard output voltages of 24V, 12V and 5V to power monitoring and control circuits in the system. The PVxx-29Bxx simplifies the wiring design reducing cost of system manufacturing and maintenance when compared with AC power or battery power. This converter also features multiple protection functions that improve system safety when a breakdown occurs.

By Min Qin, FAE, MORNSUN

Paris 2015 Global Climate conference achieved a carbon emission reduction agreement that is legally binding and practical to all parties, which further propel the development and popularity of the new green energy technology, e.g. photovoltaic industry, wind power. In 2015, China has passed Economic and Social Development 13th Five-Year Plan, which includes the continuous development plan for the PV power market and it aims to build more PV power facility to offer 150 GW. With the support of domestic and abroad policy, the request of the market, as well as the development of Energy Internet, PV power will grow in scale will offer more intelligent control, which is beneficial to reduce the cost of photovoltaic, promote technological innovation and update the industry. The common goal of the global PV power industry is to create a type of clean energy with lower costs and higher-efficiency. Currently, the PV power system is built on the design of 1000Vdc input. However, the line loss can be reduced if the system can accept higher voltage input, which can have an extra efficiency increment of 1.5%~2.0%. The market research report by GTM estimated that the 1500Vdc PV power system would account

for 9% of the global demand in 2016, which is equal to 4.6GW. Therefore, the 1500Vdc PV power system will inevitably be a growing trend in the power industry.

Basic structure and request of the PV power generation system

PV power generation system contains solar panel, combiner box, DC power distribution cabinet, inverter and boosting transformer (Diagram 1: PV Power generation System). In this system, in order to reduce the wiring between solar panel arrays and the inverters, the arrays are built by group, and connected in parallel to get electric combination into the solar combiner, and then the DC will be provided through DC cabinet to solar inverter and then into the power grid.

The output voltage of solar panel arrays varies significantly for sun light from different regions, seasons and time. And the solar combiner needs to detect every group of the solar panel array's voltage, current, power and anti-thunder condition, and realize the functions of failure warning, locating and communication. The solar inverter needs to detect the voltage, current and drive the control board while converting the DC to AC.

Because the solar panel arrays output is normally higher than 1kv, conventional power module cannot accept the voltage from the high-voltage line as input, if adopting the solution of external power for driving multiple detection units for solar combiners and inverters, unstable operating voltage, wiring and single shorted circuit problems may occur and cause power failure of the whole detection system.

Therefore, these factors of a power supply should be considered for PV power system equipment:

- Input voltage and output voltage : e.g. 200-1500VDC input and standard output of 12V/15V/24V
- Isolation between primary side and secondary side: 4000VAC
- Multiple Protections: input under-voltage protection, reverse input protection output overcurrent protection, short-circuit protection and output over-voltage protection, etc.
- High Reliability in harsh environment
- Output voltage:12V/15V/24V available

To meet the PV power generation application requirement, MORNSUN released a series of DC-DC converters with 200-1500VDC input and 4000VAC isolation. Additionally, MORNSUN has a pack of DC-DC solutions which can ensure the safety isolation in different units of the circuit.

Power Solution for Monitoring Unit of PV Combiner Box

In order to enhance the reliability and practicality, PV combiner box is equipped with DC Anti-thunder protection module, DC fuse, circuit breaker and some functional circuits, such as Control and Processing, Working State Monitoring and Communication circuits, etc.

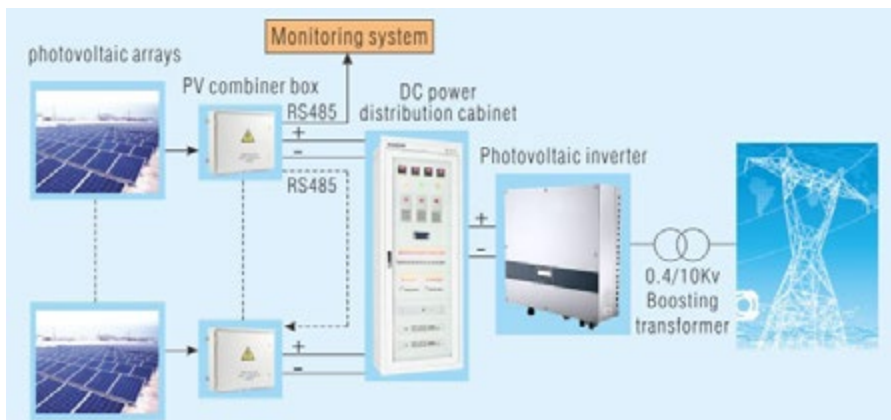

Figure 1: PV power generation system

Diagram 2 shows a typical monitoring unit solar combiner box. With the feature of 200-1500VDC input, 4000VAC isolation of PVxx-29B24, it becomes much simpler to get the power source from the solar panel array and convert it to 24VDC for the monitoring unit. DC-DC converter F0505S-1WR2 is used to drive the hall sensor with isolation between high and low voltage. DC-DC converter B0503XT-2WR2 provides the 3.3V isolated DC for MCU. The transceiver TD501D485H integrates the isolated serial communication signal and isolated power, which can impede electromagnetic interference and avoid ground loop interference. This solution is functionally meets the requirements and also provides safety isolation, which is simple and reliable.



Figure 4: Converter

Power Solution for Monitoring Unit of Photovoltaic Inverter

In the front end, the combiner box is used to combine the current, and after the DC cabinet monitoring, the DC voltage will be converted into AC through the inverter. The converting process of the inverter is also needs to be monitored, controlled and communicated to ensure the inverted voltage can meet the requirement. This monitoring unit can accept the wide input range of 200-1500VDC from the bus.

As Diagram 3 shows, PVxx-29B24 gets the power source from high-voltage bus and step down to 24VDC, and the low-drop regulator K7805-500R3 and K7815-500R3 can provide the right voltage with high efficiency for the circuit behind it. B0503XT-2WR2 provides the 3.3V isolated DC for MCU. The transceiver TD501D485H integrates the isolated serial communication signal and isolated power, which can impede electromagnetic interference and avoid ground loop interference. QP12W08S-37 is isolation DC-DC integrated IGBT driver, which can simplify the design and improve reliability.

Brief Introduction for PVxx-29Bxx DC-DC Converter

PVxx-29Bxx is a high reliability DC-DC converter with 200-1500VDC input, 4000VAC isolation and built-in multi-protection functions, which can be widely used in PV generation and high-voltage inverter application as a stable and reliable power supply,

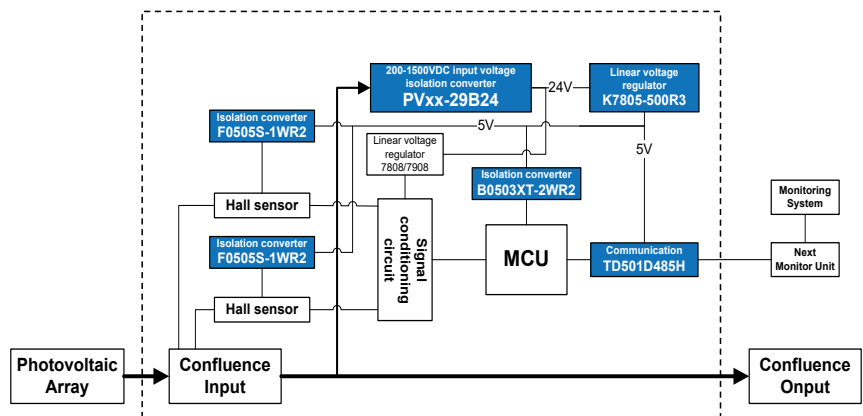

Figure 2: Power Solution for Monitoring Unit of PV Combiner Box

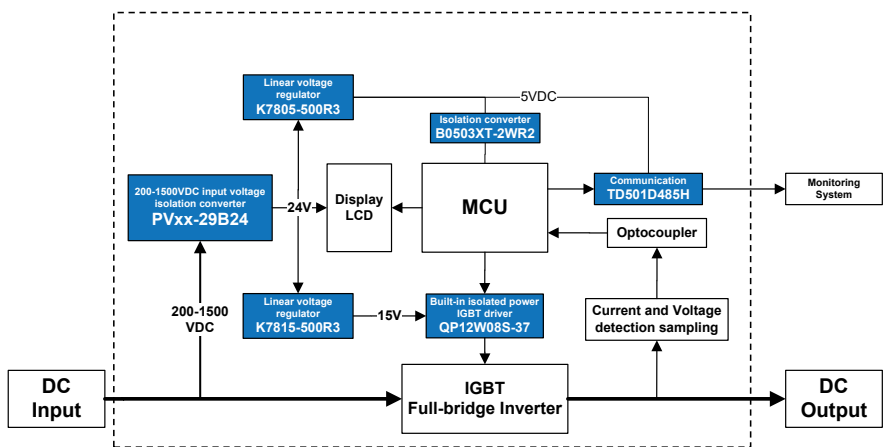

Figure 3: Power Solution for Monitoring Unit of Photovoltaic Inverter

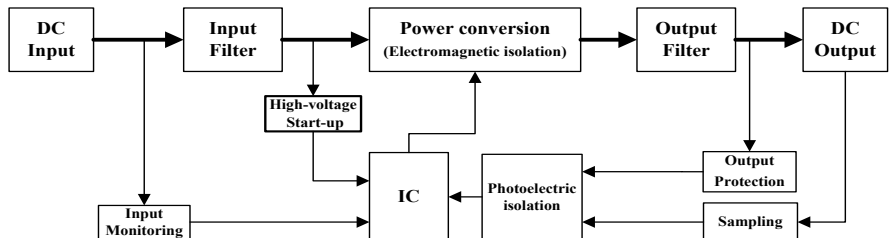

Figure 5: the Principle diagram of PVxx-29Bxx series

Features:

- Ultra wide input voltage range: 200 ~ 1500VDC
- Industrial grade operating temperature: -40℃~+70℃
- 4000VAC I/O isolation voltage
- High efficiency, Low ripple & noise
- Input under-voltage protection, reverse input protection, Output short circuit, over-current, over-voltage protection
- Meet EN62109 approval, UL508(Pending)
- PCB mounting, DIN-Rail mounting available

The block diagram of PVxx-29Bxx is shown on diagram 5. It uses fly-back topology, using a mature and reliable PWM control IC, and adopting the design of high voltage dual transistors in series and isolated power. The high-voltage start-up circuit employs

MORNSUN's patented high-voltage start up technology, and has multiple protection circuits, such as input under-voltage, output over current, and short-circuit protection to achieve high reliability.

Conclusion

In summary, PV energy is a promising market and MORNSUN is developing the right product for the right application of this industry for cleaner power. Targeting the specific requirement of 1500VDC solar PV system monitoring, MORNSUN offers the PVxx-29Bxx which can accept 1500Vdc input along with offering a full suite of power solutions, to simplify customers' design, save cost, and ensure the system reliability.

www.mornsun-power.com

E-mail: info@mornsun.cn